

Inboard Mount

John Deere

2009-2013

8295RT, 8320RT, 8345RT

8310RT, 8335RT, 8360RT

IVT Trans.

List Price: \$5,016.00

Limitations may apply.
Please consult API Sales at
800-288-1117

PARTS LIST			
ITEM	QTY	PART NUMBER	DESCRIPTION
1	1	10-1722R	Front Pan Bracket JD 8 RT R
2	1	10-1722L	Front Pan Bracket JD 8 RT L
3	1	10-1720R	Rear Pan Bracket JD 8 RT
4	1	10-1720L	Rear Pan Bracket JD 8 RT L
5	2	10-1019	JD 8RT Inside Pan
6	1	10-1721R	Axle Brace JD 8 RT
7	1	10-1721L	Axle Brace JD 8 RT L
8	8	10-1032	JD 8RT Inboard Pan Tab

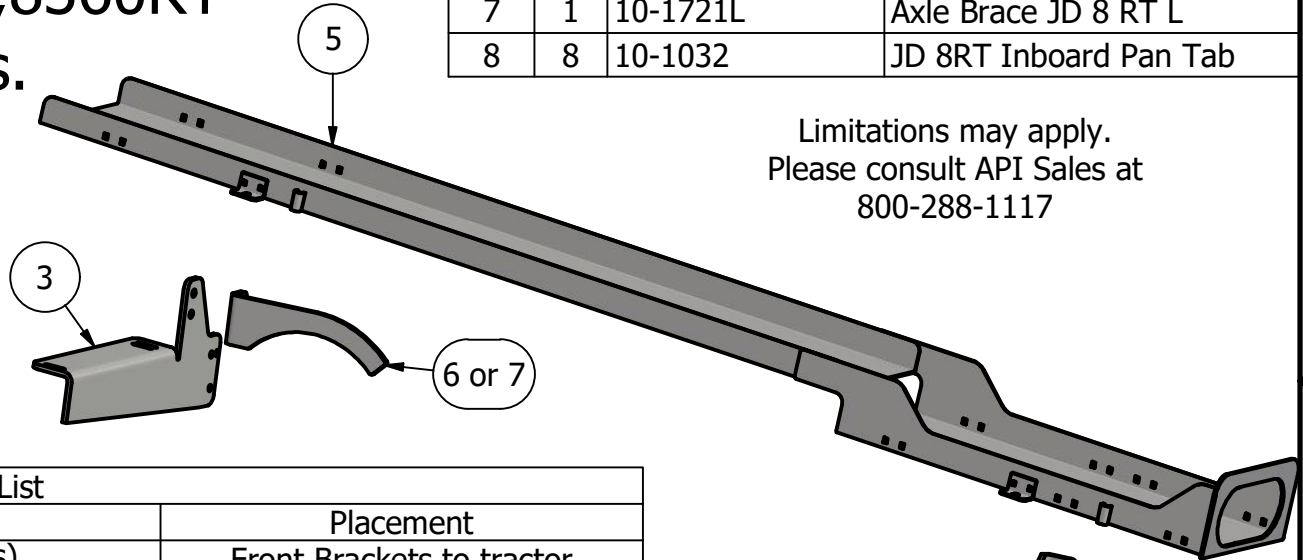

Bolt List

QTY	Description	Placement
6	20 mm x 60 mm x 10.9 Bolts (IVT Trans)	Front Brackets to tractor
10	20 mm Harden Flatwashers	Front Brackets and Axle Brace
6	16 mm x 45 mm x 10.9 Bolts	Rear Bracket to Tractor
6	16 mm Harden Flatwashers	
4	3/4 x 2 1/2 Bolts	Rear Bracket to Rear Axle Brace
4	3/4 in Lock Washers	
4	3/4 in Nuts	
8	1/2 x 1 1/2 Bolts	Tabs to Brackets
16	1/2 in Flat Washers	
8	1/2 in Lock Washers	
8	1/2 in Nuts	
4	Nylon Straps	Hold tank to Pan
8	1/2 in J bolts	
8	1/2 in Lock Nuts	
16	3/8in x 1in Carriage Bolt	Tabs to Pan
16	3/8in Flange Nut	

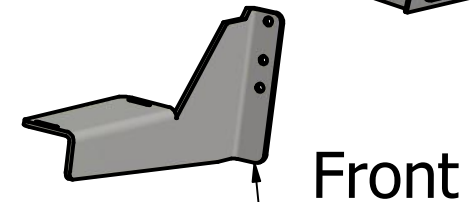

210 ID: JD-8TRTIVT-0913-INB-210S